

EDGE

O V E N S

EDGE3870G-G2

38" WIDE BELT - 70" LONG CHAMBER



The EDGE 3870 has a 38" wide belt with a 70" long baking chamber, the ideal size for very high output stores with additional room to grow. The 38" wide belt gives you the flexibility to work with the traditional 12" pizzas and the larger 16" size without compromising the belt efficiency.

The innovative single burner, single blower design and component quality allows the EDGE3870 to maintain an extremely narrow footprint which offers unrivalled space efficiency when compared with similar specification ovens from rival manufacturers.

All EDGE models utilize an inverter-driven direct drive motor, offering super quiet operation compared to belt-driven fan systems. Front of house oven operation is no longer an issue, giving further flexibility to kitchen design and oven position.

The intelligent gas burner system precisely controls gas usage, and adjusts according to the demands placed on the oven. EDGE has also heavily insulated the oven end panels and the oven's body throughout, ensuring that heat stays where it should, in the oven! Reducing energy consumption and consequently your energy bills.

EDGE's innovative G2 controller provides the operator with a new and intuitive way of interacting with their oven. The robust touch screen offers simple time, temperature, main fan and belt direction adjustment, as well as recipe creation, USB data transfer and detailed fault diagnostics and system monitoring. Further improving EDGE ovens reliability and customer support.



STANDARD FEATURES & BENEFITS

- Robust touch screen G2 controller offering detailed fault diagnostics, recipe creation, USB data transfer and EDGE app interactivity.
- Intelligent gas burner system providing unrivalled gas efficiency
- Stackable up to three ovens high, with staff friendly conveyor belt working heights
- Brushless drive conveyor system, with automatic belt jam detection and shut-off
- Reversible belt direction (via G2 controller)
- Modular and removable control cabinet
- Front loading window
- Removable crumb pans
- Insulated and removable end panels
- Split belt option with individually controlled speed settings
- Conveyor speed range 3:00 - 30:00 minutes
- Superior stainless steel construction inside and out which is manufactured to exacting tolerances

OPTIONAL FEATURES

- Split belt option with individually controlled speed settings
- Fire suppression system piping and brackets
- Stainless steel cool front fascia
- Colored cool front fascia to match brand panetones
- Left hand side control cabinet on request
- High speed conveyor range offering 2:00 minute bake option

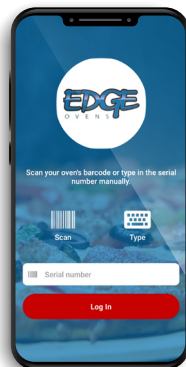

MF&B Restaurant Systems
119 ICMI Road, Ste 300,
Dunbar, PA 15431, USA



www.edgeovens.com
1.888.480.EDGE
sales@edgeovens.com



PLAN VIEW

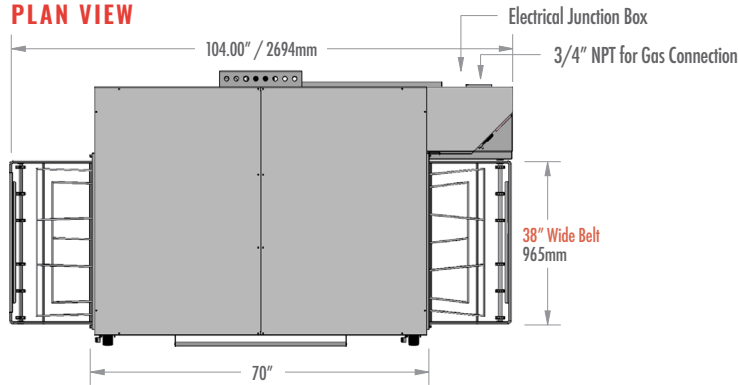

XX-LARGE PIZZA (18") LOADING PLAN

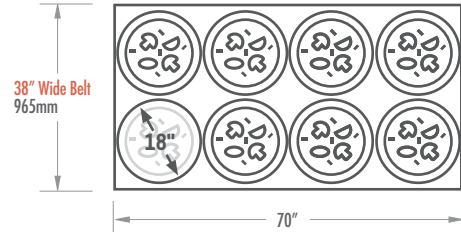

FRONT VIEW - EDGE3870-3



SIDE VIEW - EDGE3870-3

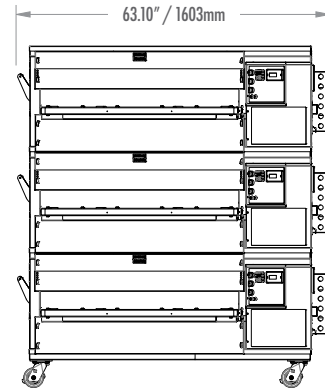

FRONT VIEW - EDGE3870-2

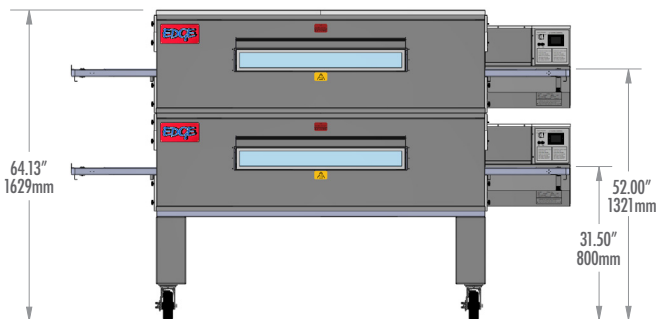

SIDE VIEW - EDGE3870-2

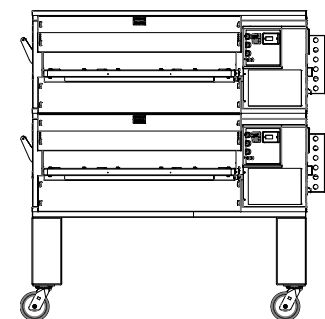

FRONT VIEW - EDGE3870-1

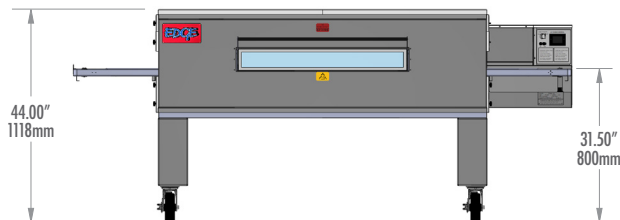

SIDE VIEW - EDGE3870-1

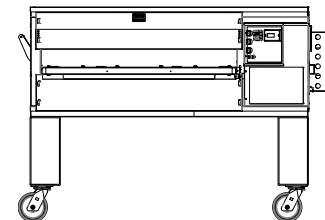

MODEL	DECKS	BELT WIDTH	CHAMBER LENGTH	DIMENSIONS (W X D X H)	SHIPPING WEIGHT
EDGE3870G-1	1	38" (965mm)	70" (1778mm)	104.00" x 63.10" x 44.00" / 2694 x 1603 x 1118mm	
EDGE3870G-2	2	38" (965mm)	70" (1778mm)	104.00" x 63.10" x 64.13" / 2694 x 1603 x 1629mm	
EDGE3870G-3	3	38" (965mm)	70" (1778mm)	104.00" x 63.10" x 68.50" / 2694 x 1603 x 1740mm	



EDGE3870G-G2

38" WIDE BELT - 70" LONG CHAMBER



ELECTRICAL SERVICE

Each oven deck requires a dedicated electrical supply as dictated by its area type (US or international). Each deck should be provided with a dedicated suitably sized circuit breaker. Neutral must be grounded at electrical service and receptacle properly polarized. Voltage, phase and hertz should be verified prior to oven commissioning.

RECOMMENDED MINIMUM CLEARANCES

Please allow a minimum of 6" (152mm) at the rear of the oven to combustible surfaces. An additional 24" (610mm) clearance is recommended to the right hand side of the oven, to allow access to oven componentry for servicing purposes. It is also strongly recommended that other cooking equipment (frying equipment in particular), is kept at least 24" from the oven control cabinet to avoid grease ingress.

VENTILATION

Ventilation is required on all ovens. Local codes prevail. A powered ventilation hood is required to remove heat and grease laden vapors. Provisions must be made to replenish at least 80% of the amount of air that is extracted from the building. The hood and HVAC installation must meet local building and mechanical codes.

We recommend when using a canopy style ventilation hood, that it overhangs the oven by a minimum of 12" (305mm) in each direction. Recommended hood size* for an EDGE3870 in single, double or triple, is 132" (3352mm) [W] x 84" (2133mm) [D] x 24" (610mm) [H].

*Always check with local authority for compliance before purchasing hood system.

GAS SUPPLY

Gas supply lines must be installed by a qualified personnel and meet all local codes. An appropriately sized gas meter and regulator must be sized accordingly and take into consideration any additional catering equipment or gas appliances (such as water boilers and furnaces).

We recommend a minimum pipe size of 2" (51mm) when running ovens only. Gas supply pressures are dependent on local gas type and on all applicable codes. Agency approved 3/4" (19mm) NPT flexible hoses with a maximum length of 72" (1829mm) should be used for each oven deck.

OVEN SPECIFICATIONS	CAVITY	SINGLE	DOUBLE	TRIPLE
Power (kW)	54.2kW	54.2kW	108.6kW	162.6kW
Power (BTU/Hr)	185,000	185,000	370,000	555,000
Natural Gas Supply	6" - 8" W.C. / 15 - 20 mbar			
LPG Supply	10" - 13" W.C. / 25 - 32 mbar			
Electric Supply (US)	120V / 1φ / 60Hz / 5.5A			
Electric Supply (International)	230V / 1φ / 50Hz / 3A			



WARRANTY

All new EDGE ovens installed in the United States are provided with a five (5) year parts and labor warranty starting from the date of start-up/check-out or sixty-two (62) months from the purchase date, whichever occurs first (USA only). All ovens installed in locations other than in the United States are warranted for five (5) year parts, labor length to be confirmed by local distributor.

All warranties are subject to terms and conditions which are available on request.

OUTPUT CAPACITY ESTIMATES | PIES PER HOUR PER OVEN DECK

EDGE MODEL	PIZZA SIZE (INCHES)	BAKE TIME (MINUTES)										
		4:00	4:30	5:00	5:30	6:00	6:30	7:00	7:30	8:00	8:30	9:00
EDGE3870	10"	445	395	356	323	296	274	254	237	222	209	198
	12"	301	268	241	219	201	185	172	161	151	142	134
	14"	216	192	173	157	144	133	123	115	108	102	96
	16"	162	144	129	117	108	99	92	86	81	76	72
	18"	125	111	100	91	83	77	71	67	62	59	55

OVEN FAMILY IMAGES



MF&B Restaurant Systems reserves the right to make changes to the design or specifications without prior notice.